

# PD series

## HARD TOP JAWS



Fig1

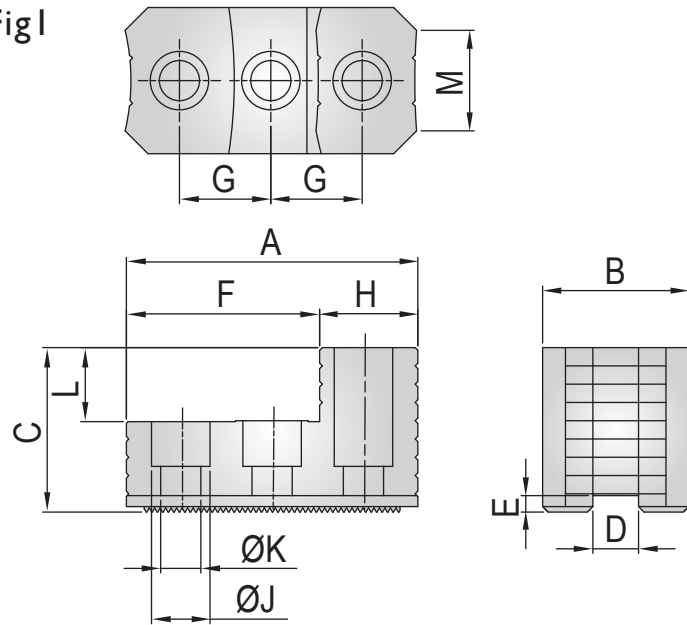
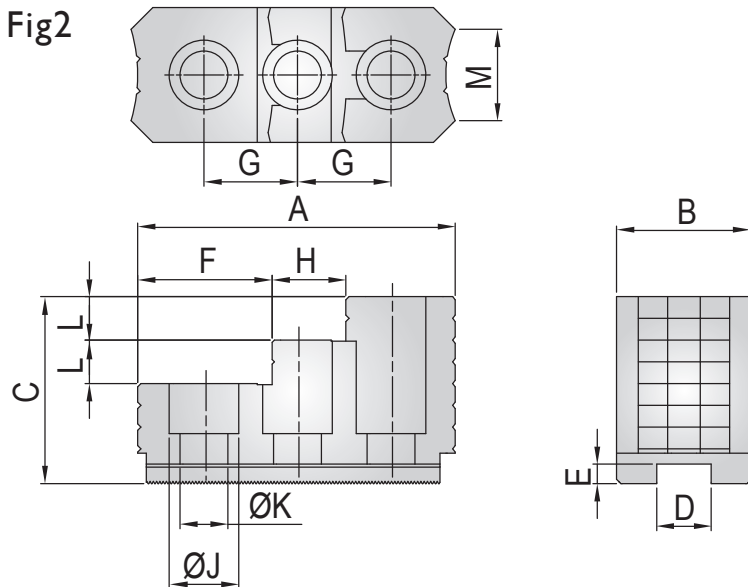

Fig2



### SERRATION

| Model    | A     | B  | C  | D    | E | F    | G  | H    | J  | K  | L  | M  | Serration Pitch | Reference Drawing | Weight (kg) |
|----------|-------|----|----|------|---|------|----|------|----|----|----|----|-----------------|-------------------|-------------|
| PD1-15   | 149   | 62 | 86 | 25.5 | 9 | 63   | 43 | 34   | 32 | 22 | 20 | 42 | 1.5*60°         | Fig2              | 3.1         |
| PD1-21-1 | 159.5 | 80 | 84 | 25   | 9 | 100  | 50 | 59.5 | 32 | 22 | 40 | 42 | 3.0*60°         | Fig1              | 3.3         |
| PD1-32-1 | 159.5 | 80 | 90 | 25   | 9 | 97.5 | 50 | 62   | 32 | 22 | 40 | 60 | 3.0*60°         | Fig1              | 5.1         |

• If the dimension and specification change, please take the confirmation drawing as a standard.